



**DOWNLOAD
STEP-BY-STEP
INTERACTIVE
ASSEMBLY GUIDE**



CHAR-BROIL BBQ GUIDE APP
English, French, German, Danish



ADVANTAGE PRO SERIES 4 BURNER

MODEL NUMBER
468505422
468173422

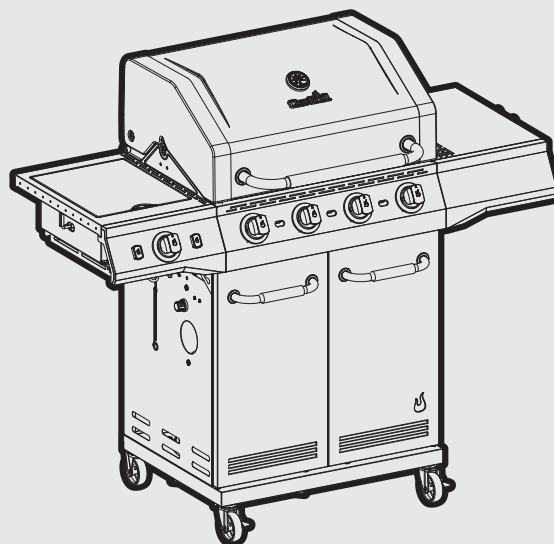

GB	Operating Instructions	2	Assembly Instructions	126
CH, FR	Mode d'emploi	9	Instructions d'assemblage	126
LU, AT, CH, DE	Betriebsanweisungen	16	Montageanweisungen	126
CH, IT	Istruzioni per l'uso	23	Istruzioni per il montaggio	126
LU, BE, NL	Gebruiksaanwijzingen	30	Montage-instructies	126
SE	Användning	36	Montering	126
FI	Käyttöohjeet	42	Kokoamisohjeet	126
ES	Instrucciones de funcionamiento	48	Instrucciones de armado	126
PT	Instruções para Operação	54	Instruções para Montagem	126
DK	Brugsanvisning	60	Monteringsvejledning	126
NO	Instruksjoner for bruk	66	Imontering	126
SK	Návod na používanie	72	Návod na montáž	126
IS	Notkunarlæðbeiningar	78	Smalamálsskipana	126
CZ	Návod k obsluze	84	Montážní návod	126
IL	הוראות הפעלה,	90	הוראות הרכבה	126
RO	Instrucțiuni de utilizare	96	Instrucțiuni de asamblare	126
GR	Οδηγίες λειτουργίας	102	Οδηγίες συναρμολόγησης	126
HU	Használati utasítások	108	Szerelési útmutató	126
BG	Инструкции за работа	114	Инструкции за сглобяване	126
SI	Navodila za uporabo	120	Navodila za montažo	126



INSTALLER/ASSEMBLER:

Leave this manual with consumer.

CONSUMER:

Keep this manual for future reference.

Questions:

If you have questions during assembly or use of this appliance contact your local dealer.



DANGER



If you smell gas:

1. Shut off gas to the appliance.
2. Extinguish any open flames.
3. Open lid.
4. If odor continues, keep away from the appliance and immediately call your gas supplier or your fire department.



WARNING



1. Do not store or use petrol or other flammable liquids in the vicinity of this or any other appliance.
2. A gas cylinder not connected for use shall not be stored in the vicinity of this or any other appliance.



CAUTION



- Read and follow all safety statements, assembly instructions and use and care directions before attempting to assemble and cook.
- Some parts may contain sharp edges. Wearing protective gloves is recommended.

Grease Fires

- Putting out grease fires by closing the lid is not possible. Barbecues are well ventilated for safety reasons.
- Do not use water on a grease fire, Personal injury may result. If a persistent grease fire develops, turn knobs and gas cylinder off.
- If appliance has not been regularly cleaned, a grease fire can occur that may damage the product. Pay close attention while preheating or burning off food residue to insure that a grease fire does not develop. Follow instructions on general appliance cleaning and cleaning the burner assembly to prevent grease fires. The best way to prevent grease fires is regular cleaning of the appliance.
- Do not leave barbecue unattended while preheating or burning off food residue on HI. If barbecue has not been regularly cleaned, a grease fire can occur that may damage the product.



WARNING



For Safe Use of Your Appliance and to Avoid Serious Injury:

- **USE OUTDOORS ONLY. NEVER USE INDOORS.**

Read the instructions before using the appliance.

Always follow these instructions.

- Do not move the appliance during use.
- Accessible parts may be very hot. Keep young children away. Do not let children operate or play near appliance.
- Turn off the gas supply at the cylinder after use.
- This appliance must be kept away from flammable materials during use.
- Do not block holes in sides or back of appliance.
- Check burner flames regularly.
- Do not block venturi openings on burner.
- Use appliance only in well-ventilated space. NEVER use in enclosed space such as carport, garage, porch, covered patio, or under an overhead structure of any kind.
- Do not use charcoal or ceramic briquets in a gas appliance.
- **DO NOT** cover grates with aluminum foil or any other material. This will block burner ventilation and create a potentially dangerous condition resulting in property damage and/or personal injury.
- **Use appliance at least 1m from any wall or surface.**
- Maintain 3m clearance to objects that can catch fire or sources of ignition such as pilot lights on water heaters, live electrical appliances, etc.

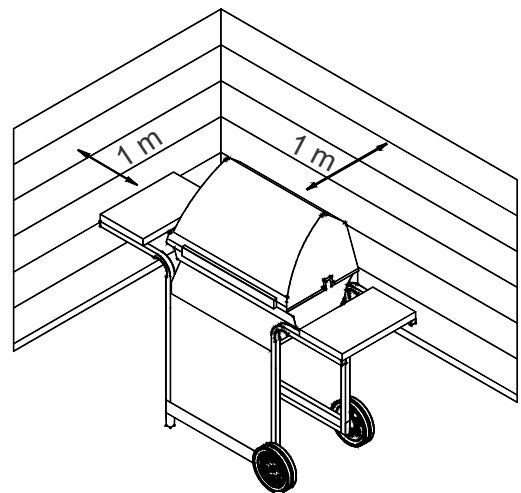

- NEVER attempt to light burner with lid closed. A buildup of non-ignited gas inside a closed appliance is hazardous.
- Always turn off gas at cylinder and disconnect regulator before moving gas cylinder from specified operating position.
- Never operate appliance with gas cylinder out of correct position specified.
- Do not modify the appliance. Any modification of the appliance may be dangerous. Sealed parts are not to be manipulated by the user. Do not disassemble injectors.

Safety Tips

- Before opening gas cylinder valve, check the regulator for tightness.
- When appliance is not in use, turn off all control knobs and gas.
- Use long-handled barbecue utensils and oven mitts to avoid burns and splatters. Use protective gloves when handling hot components.
- Maximum load for hot plate, if equipped, and side shelf is 4.5 Kg. Cooking vessel minimum dia 200mm and maximum dia. 260 mm. **NOTE:** Your barbecue may NOT be equipped with a Hot plate!
- The grease cup (if equipped) must be inserted into appliance and emptied after each use. Do not remove grease cup until appliance has completely cooled.
- Be very careful when you open the lid, since hot steam may escape.
- Be very careful when children, the elderly, or pets are nearby.
- If you notice grease or other hot material dripping from appliance onto valve, hose or regulator, turn off gas supply at once. Determine the cause, correct it, then clean and inspect valve, hose, and regulator before continuing. Perform a leak test.
- Do not store objects or materials inside the appliance cart enclosure that would block the flow of combustion air to the underside of either the control panel or the firebox bowl.
- DO NOT disconnect or change gas container within 3m of an open flame or other ignition source.

Cylinder Placement

Cylinder of 6 kg or less may be placed on the ground under the side shelf or inside the appliance in place provided. Larger cylinders are to be placed under side shelf or behind the barbecue only. Cylinders placed in the appliance shall have a maximum diameter of 340mm and maximum height of 400mm. Cylinders placed on the ground shall not be placed under the hot plate.

Regulator Requirements



A regulator must be used with this appliance. Use only gas regulator supplied with your barbecue. If a regulator is not supplied then use only regulator certified according to EN16129 (Flow rate max. 1.5 kg/h) and approved for your country and gas specified in Technical Data.



Hose Requirements

Use only approved hose which is certified to appropriate EN standard and does not exceed 1.5m length. For Finland, the hose length shall not exceed 1.2m. Before each use, check to see if hoses are cut or worn. Make sure hose is not kinked. Replace damaged hoses before using appliance. Replace hose as required by national requirements.

Ignitor Lighting

- **Do not lean over barbecue while lighting.**
 1. Turn gas burner control valves to ○ (off).
 2. Open lid during lighting or re-lighting.
 3. Turn ON gas at LP cylinder.
 4. To ignite, push and turn burner knob to 🔥 HIGH. Immediately, push and hold ELECTRONIC IGNITOR button until the burner lights.
 5. If ignition does NOT occur in 5 seconds, turn the burner controls off ○, wait 5 minutes and repeat the lighting procedure.
 6. Repeat steps 4 and 5 to light other main burners.

	WARNING	
<ul style="list-style-type: none">• Turn controls and gas cylinder off when not in use.• Make sure that when connected hose does not touch any warm surfaces.		

	CAUTION	
<p>If ignition does NOT occur in 5 seconds, turn the burner controls ○ off, wait 5 minutes and repeat the lighting procedure. If the burner does not ignite with the valve open, gas will continue to flow out of the burner and could accidentally ignite with risk of injury.</p>		

Match-Lighting

- **Do not lean over barbecue while lighting.**
 1. Turn gas burner control valves to ○ (off).
 2. Open lid during lighting or re-lighting.
 3. Turn ON gas at LP cylinder.
 4. Place match into match holder (hanging from side panel of barbecue). Light match; then light burner by placing match through the match light hole on side of barbecue. Immediately push in and turn burner knob to the 🔥 HIGH position. Be sure burner lights and stays lit.
 5. Light adjacent burners in sequence by pushing knobs in and turning to the 🔥 HIGH position.

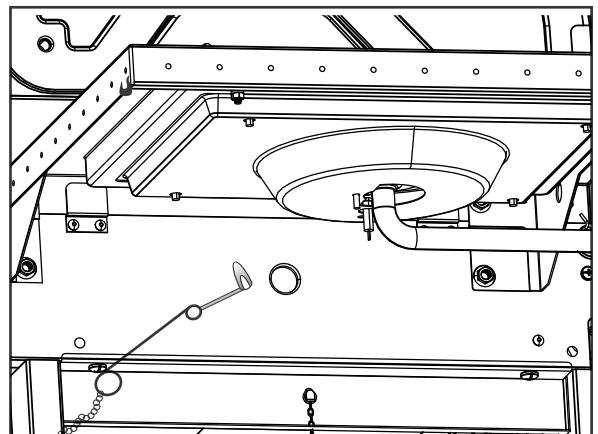

Sear Burner Ignitor Lighting

Do not lean over barbecue while lighting.

1. Turn gas burner control valves to OFF.
2. Open lid during lighting or re-lighting.
3. Turn ON gas at LP cylinder.
4. Turn Sear Burner knob to the HIGH position, push and hold ELECTRONIC IGNITOR button.
5. If Sear Burner does NOT light within 5 seconds, turn knob to OFF, wait 5 minutes, then repeat lighting procedure.

Sear Burner Match Lighting

Do not lean over barbecue while lighting.

1. Turn gas burner control valves to OFF.
2. Open lid during lighting or re-lighting.
3. Turn ON gas at LP cylinder.
4. Place lit match near burner. Immediately turn Sear Burner knob to the HIGH position. Be sure the burner lights and stays lit.

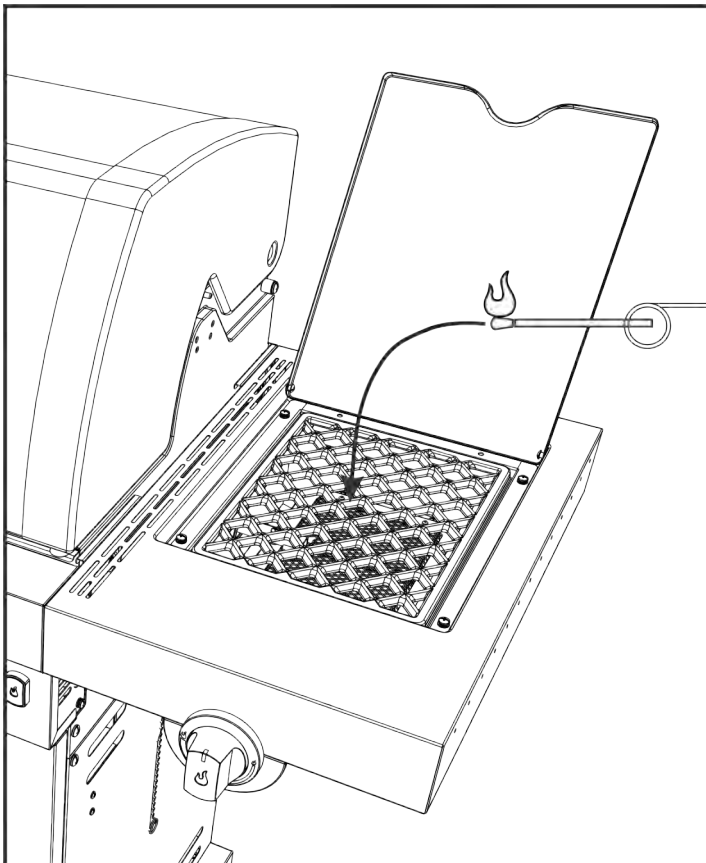

.. UTION



SPIDER ALERT!

SPIDER AND WEBS INSIDE BURNER

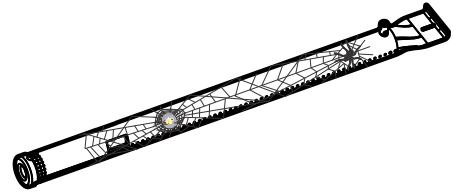

If your barbecue is getting hard to light or the flame is weak, check and clean the venturis and burners.

Spiders or small insects are known to create “flashback” problems by building nests and laying eggs in the barbecue’s venturi or burner obstructing the flow of gas. The backed-up gas can ignite behind the control panel. This flashback can damage your barbecue and cause injury. To prevent flashbacks and ensure good performance, the burner and venturi tube assembly should be removed and cleaned whenever the barbecue has been idle for an extended period of time.

Leak Testing Valves, Hose and Regulator

Leak test before first use, at least once a year, and every time the cylinder is changed or disconnected.

1. Turn all appliance control knobs to \circ .
2. Be sure regulator is tightly connected to gas cylinder.
3. Turn on Gas. If you hear a rushing sound, turn gas off immediately. There is a major leak at the connection. Correct before proceeding.
4. Brush soapy solution (mixture of half soap and half water) onto hose connections.
5. If growing bubbles appear, there is a leak. Turn off gas at cylinder immediately and check tightness of connections. If leak cannot be stopped do not try to repair. Call for replacement parts.
6. Always turn off gas at cylinder after performing leak test.

IF APPLIANCE FAILS TO LIGHT

- Make sure gas is turned on at cylinder.
- Make sure there is gas in the cylinder.
- Does the ignitor make a sparking noise?
 - If yes check for spark at burner.
 - If no spark check for damaged or loose wires.
- If wires are OK check for cracked or broken electrode, replace if needed.
- If wire or electrodes are covered by cooking residue, clean electrode tip with alcohol wipe if needed.
- If needed replace wires.
- If no sound check battery.
- Make sure battery is installed correctly.
- Check for loose wire connection at module and switch.
- If ignitor continues to not work then use match.

Cleaning the Burner Assembly

Follow these instructions to clean and/or replace parts of burner assembly or if you have trouble igniting barbecue.

1. Turn gas off at control knobs and LP cylinder.
2. Remove cooking grates and heat tents.
3. Remove carryover tubes and hardware securing burners.
4. Detach electrode from burner.

NOTE: Removal/Detachment method will depend on the burner configuration. See different configurations in illustrations below.

5. Carefully lift each burner up and away from valve openings.

We suggest three ways to clean the burner tubes. Use the one easiest for you.

- A. Bend a stiff wire (a light weight coat hanger works well) into a small hook. Run the hook through each burner tube several times.



- B. Use a narrow bottle brush with a flexible handle (do not use a brass wire brush). Run the brush through each burner tube several times.

- C. **Wear eye protection:** Use an air hose to force air into the burner tube and out the burner ports. Check each port to make sure air comes out each hole.

6. Wire brush entire outer surface of burner to remove food residue and dirt.
7. Clean any blocked ports with a stiff wire such as an open paper clip.
8. Check burner for damage due to normal wear and corrosion, some holes may become enlarged. If any large cracks or holes are found, replace burner.

VERY IMPORTANT: Burner tubes must reengage valve openings. See illustrations at right.

Correct burner-to-valve engagement

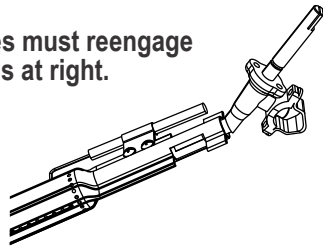

9. Attach electrode to burner.
10. Carefully replace burners.
11. Attach burners to brackets on firebox.
12. Reposition carryover tubes and attach to burners. Replace heat tents and cooking grates.
13. Before cooking again on barbecue, perform a "Leak Test" and "Burner Flame Check".

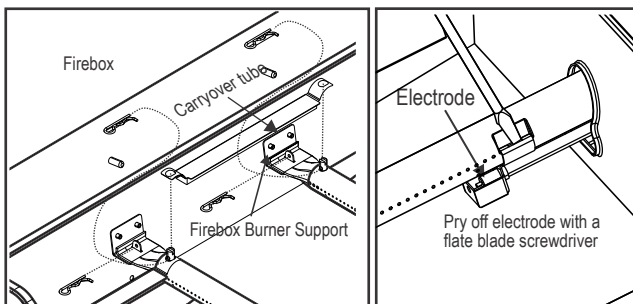

Storing Your Appliance

Clean cooking grates.

Store in dry location.

When gas cylinder is connected to appliance, store outdoors in a well-ventilated space and out of reach of children.

Cover appliance if stored outdoors.

Store appliance indoors ONLY if gas cylinder is turned off and disconnected, removed from appliance and stored outdoors.

When removing appliance from storage check for burner obstructions.

General Appliance Cleaning

Periodic cleaning of this grill is necessary, as grill fires can occur when grease and food debris collect in the bottom of the grill.

After each use, remove any remaining food particles from the cooking grate and inside of the grill using a Char-Broil Cool-Clean Brush. Afterwards you could spray Char-Broil Grate Cleaner generously onto the grate, allow it work for 10 minutes and wipe off with a wet cloth or brush. Perform grill cleaning after the grill has cooled down.

- Do not mistake brown or black accumulation of grease and smoke for paint. Interiors of gas barbecues are not painted at the factory (and should never be painted). Apply a strong solution of detergent and water or use a appliance cleaner with scrub brush on insides of appliance lid and bottom. Rinse and allow to completely air dry. Do not apply caustic appliance/oven cleaner to painted surfaces.
- Plastic parts: Wash with warm soapy water and wipe dry. Do not use abrasive cleaners, degreasers or a concentrated appliance cleaner on plastic parts. Damage to and failure of parts can result.
- Porcelain surfaces: Because of glass-like composition, most residue can be wiped away with baking soda/water solution, glass cleaner or Char-Broil Grate Cleaner. Use nonabrasive scouring powder for stubborn stains.
- Painted surfaces: Wash with mild detergent or cleaner and warm soapy water or Char-Broil Grill Cleaner. Wipe dry with a soft nonabrasive cloth.
- Cooking surfaces: Ensure no loose bristles remain on cooking surfaces prior to grilling. While grill is hot, it is only recommended to clean cooking surfaces using the Char-Broil Hot-Clean Replacement head (on the Char-Broil Cool-Clean Premium Brush).

◆◆ CLEAN Setting

Your grill is equipped with an innovative CLEAN setting that allows for hassle-free grill cleaning. The high heat generated from the burners will turn all remaining food debris to ash.

Follow these steps:

- After you are done grilling, adjust all main burners to CLEAN setting and remain for approximately 12 – 15 minutes
- After approximately 12 – 15 minutes, adjust all main burners to OFF setting and allow grill to cool
- Once the grill is cool, use a Char-Broil Cool-Clean Brush to remove any remaining debris and dispose of the ash
- To get extra-shiny results, use the Char-Broil Grate Cleaner as a last step. Spray generously onto the grate, allow it work for 10 minutes and wipe off with a wet cloth or brush.

IMPORTANT! PLEASE READ!

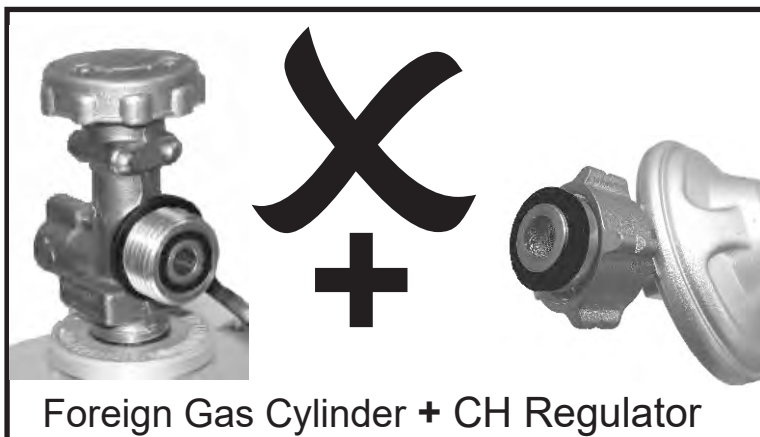
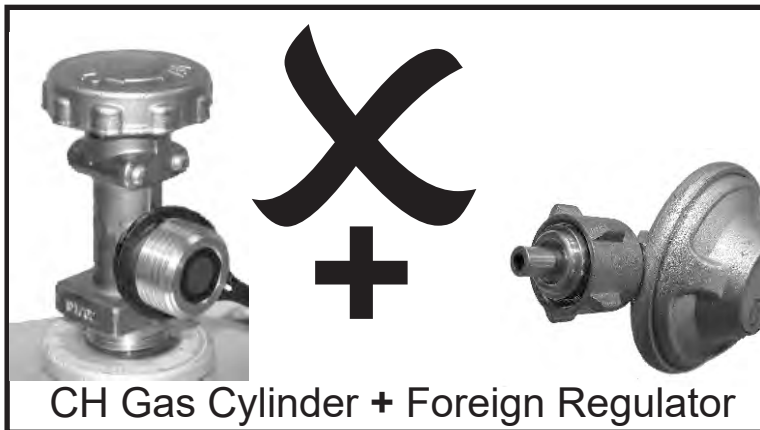
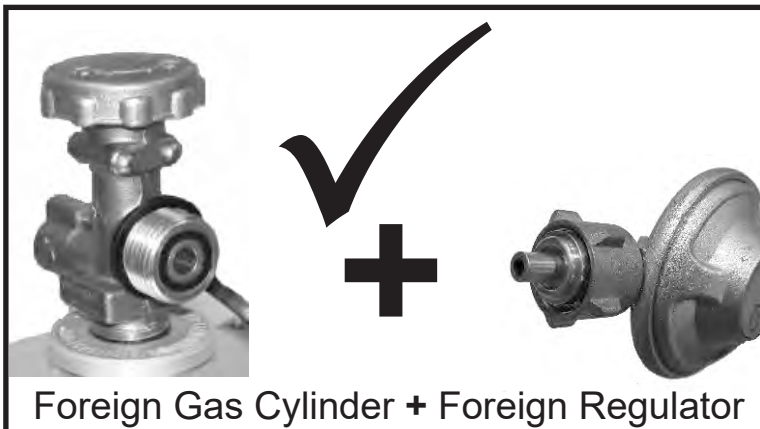
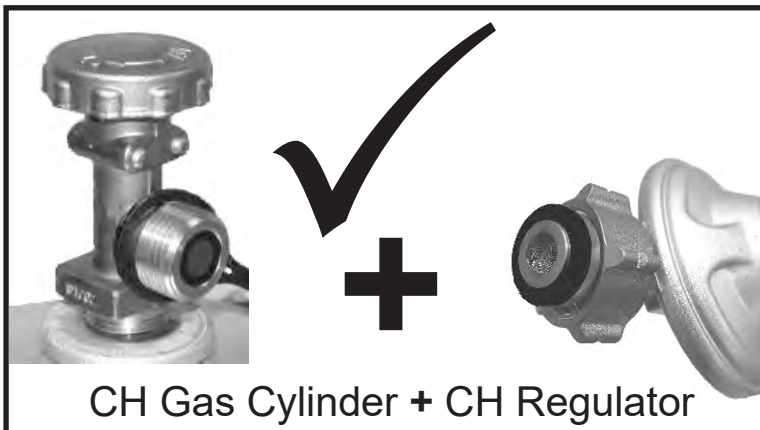

A regulator must be used with this appliance. Use only the gas regulator supplied with your barbecue. If a regulator is not supplied then use only a regulator certified according to EN16129 (Flow rate max. 1.5 kg/h) and approved for your country and gas specified in Technical Data.

For Switzerland Only

There is a danger of fire and explosion with gas appliances which are equipped with foreign pressure regulators and are not compatible with the gas tanks and gas regulators available in Switzerland

Due to the different sealing systems, it is impossible to properly seal the regulator to the gas tank. Gas will escape here and can be ignited by flame or sparks. A life-threatening explosion, and/or property damage can result. Swiss and German tanks and regulators cannot be intermixed.

For safety reason, please check your grill regulator and gas tank connection and make sure it follows in one of the allowed cases shown in the pictures.

Perform a leak check each time you connect your grill to the gas tank.

Searing Side Burner Tips:

- Always be sure to preheat the Searing Side Burner for 6-8 minutes with the lid open before use. This will help prevent food from sticking to the grate while searing.
- The Searing Side Burner can be used to provide a sear to your food, or as a traditional side burner for a pot or skillet. Cast iron, carbon steel, and stainless steel cookware will all work on the Searing Side Burner.
- Avoid pouring liquid, such as a marinade or sauce, over the food while on the searing side burner. The liquid could damage the burner or clog gas ports.
- Always operate the Searing Side Burner with the lid open. The Searing Side Burner is not designed to be used with the lid closed.
- The **Char-Broil™ Side Burner Cast Iron Griddle/Plancha** (not included) works perfectly with your Searing Side Burner. Note that this is not the griddle included with your grill, which should only be used over the main burner area.
- Take care not to cover the entire cooking area of the Searing Side Burner with food or cookware. This could cause poor cooking performance.

Cleaning the Searing Side Burner:

1. After cooking directly on the Searing Side Burner cooking grate, turn the control knob to (flame logo) and light the Searing Side Burner.
2. Allow the Searing Side Burner to operate on high for 5-7 minutes with the lid open. This will burn any excess food and grease on the Searing Side Burner.
3. Turn off the Searing Side Burner, and turn off the gas.

ALLOW THE SEARING SIDE BURNER TO COOL WITH THE LID OPEN BEFORE TOUCHING ANY COMPONENTS OR CLEANING ANY FURTHER.

4. The Searing Side Burner cooking grate can be cleaned the same as the other cooking grates in the grill. Use a **Char-Broil™ Cool-Clean Brush** to scrub leftover debris off the cooking grate after each cook. For deeper cleaning, most residue can be scrubbed away with a sponge and a baking soda/water solution or **Char-Broil™ Grate Cleaner**.
5. The ceramic burner can be cleaned by using a soft brush or vacuum to remove any burnt debris created in steps 1-3.
6. To clean the interior walls of the Searing Side Burner, rinse with soapy water and scrub with a sponge. Take care not to dump water over the top of the Searing Side Burner.

TECHNICAL DATA
CHAR-BROIL, LLC

Appliance Name	Gas Barbeque/Gas Grill		
Total Nominal Heat Input	12,20 kW (888 g/h)		12,20 kW (888 g/h)
Gas Category	I3+(28-30/37)	I3B/P(30)	I3B/P(50)
Model No.	468505422		468173422
Gas Type	Butane	Propane	Butane, Propane or their mixtures
Gas Pressure	28-30 mbar	37 mbar	30 mbar
Injector Size (Dia. mm)	Barbecue: 0,72 x 4 pcs		Barbecue: 0,61 x 4 pcs
Sear Burner Injector Size (Dia. mm)	0,91 x 1 pcs		0,81 x 1 pcs
Destination Countries	GB, FR, BE, ES, IT, PT, CZ, SK, CH, CY, GR, IE, LT, LU, LV, SI	DK, NO, NL, SE, FI, IS, CZ, IT, SK, BG, CY, EE, HR, HU, LT, LU, LV, MT, RO, SI, TR	AT, DE, CH, LU, SK

Stainless steel

There are many different types (alloys) of materials that are regarded as stainless steel.

A common trait of these different types is that they may corrode (oxidize), depending on the conditions they are subjected to.

This applies to your new barbecue as well.

To ensure your barbecue retains its looks and functionality for many years, please follow the advice below.

- 1) If the barbecue has become wet or damp, make sure to wipe it dry using a cloth in order to prevent surface corrosion.
- 2) Stainless steel can rust under certain conditions. This can be caused by environmental conditions such as chlorine or salt water, or improper cleaning tools such as wire or steel wool. It can also discolor due to heat, chemicals, or grease build-up.
- 3) To maintain your appliance's high quality appearance, wash with mild detergent and warm soapy water and wipe dry with a soft cloth after each use. Baked-on grease deposits may require the use of an abrasive plastic cleaning pad. Use only in direction of brushed finish to avoid damage. Do not use abrasive pad on areas with graphics.
- 4) Grease the internal parts of the barbecue and the grids with cooking oil.

Please note:

To avoid scratching the surface and providing a basis for rust, never use steel wool or similar when cleaning stainless steel.

When cleaning, work in the same direction the stainless steel was brushed in – 'with the grain'.

Cleaning with abrasives may leave scratches.

Storing the barbecue near a coast, swimming pool or spa will cause the barbecue to corrode (oxidize).

Cover your barbecue for rust protection.